

Installation Guide for SR100 Device

 Warning: Don't connect wires with power on!

I. Install device

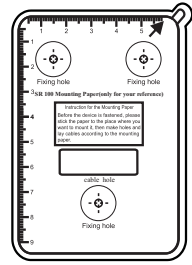

① Post the mounting template on the wall. Drill holes according to the marks on the template. (Holes for screw and wiring)

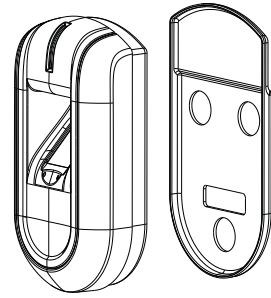

② Take off the water-proof cushion

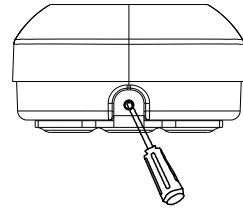

③ Take away the screw on the bottom of the device

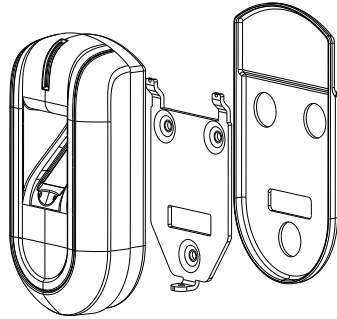

④ Release the mounting plate

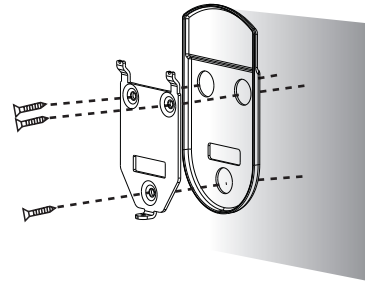

⑤ Fix the cushion and plate on the wall

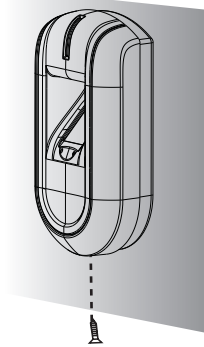

⑥ Fix the device to the plate after all wiring completed

2. Verification process

Press finger or flash card on the device. When the device gets the information, it will transmit the information to the host machine, which will verify fingerprints or card. Then corresponding prompt will be given and transmitted to the device.

- ①. blue light twinkle: normal standby state
- ②. green light on, and the buzzer "Dii..." : success in card or fingerprint verification
- ③. red light on and the buzzer " Dii...Dii..." : failure in card or fingerprint verification

III. Notice

When host device, SR100 and EM lock are powered by a single switching power adaptor, the interference of EM lock to power supply may affect the stability of the whole system. Therefore, the below power supply method is advised:

- ① Supply power to specified terminals and lock separately, namely access control and lock use different power supplies. The recommended voltage of power supply to specified terminal is 12V, and the current is 1.5A at least; the power supply to lock should follow the lock instruction strictly. Wiring diagram is as follow (NC locks for example):

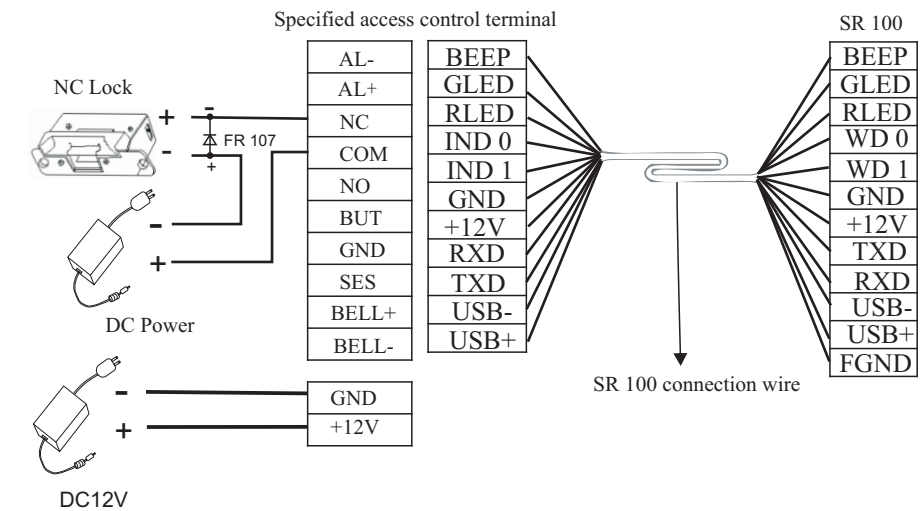

- ② Use professional access control power (the connection way of other access control power supplies refers to its own instruction) to the access control system. Wiring diagram is as follow (NC locks for example):

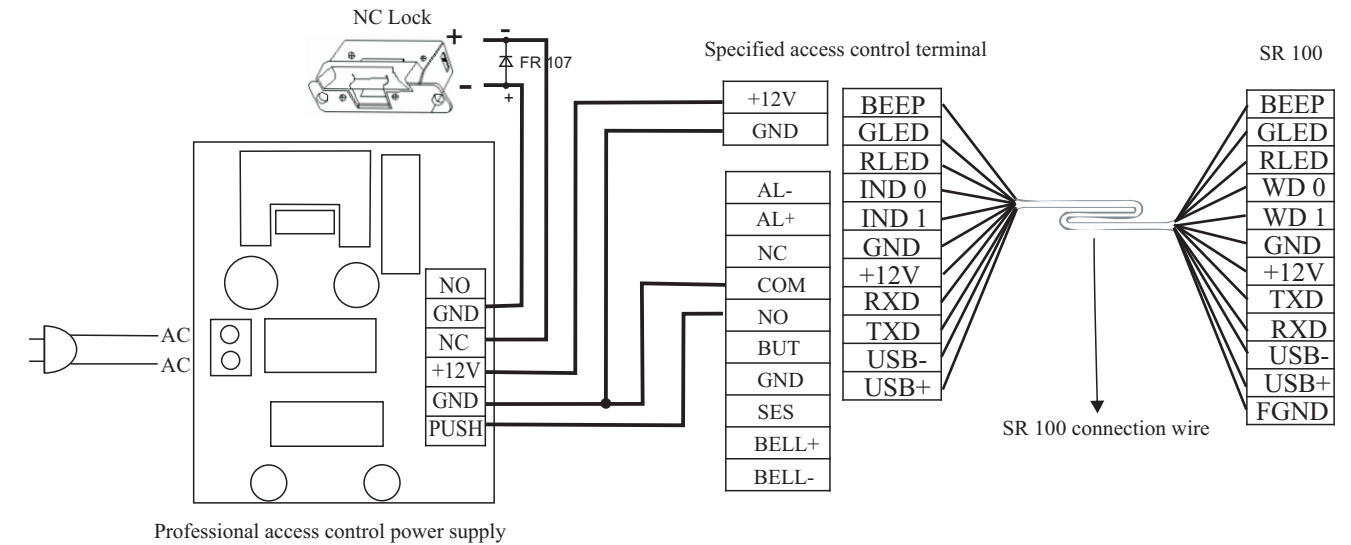

※ Remarks:

1. D card, Mifare card, HID card is optional ;
2. If you have any other questions, you can consult our commercial representative or pre-sale technical assistance.

II. Working Principle

1. Connection with host machine

The device can only be used as reader. It cannot dispose the obtained information. Therefore, it needs connecting host machine to obtain fingerprint information and transmit it to host machine for disposal through USB. The host machine is specified access control terminal which you can consult the commercial representative, Before connection, please power off the device. Connection under power-on state may bring great damage to the device.

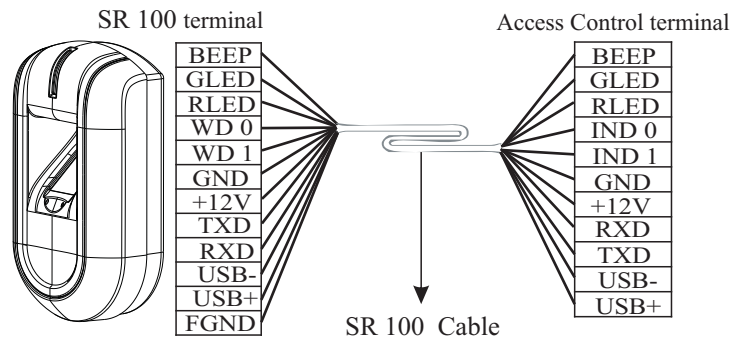

The terminal definition table of SR 100

Terminal Sequence	Terminal name	Function
1	BEEP	Signal input of buzzer
2	GLED	Signal input of green indicator
3	RLED	Signal input of red indicator
4	WD 0	Wiegand D0 output
5	WD 1	Wiegand D1 output
6	GND	GND
7	+12V	12V power input (positive pole)
8	TXD	RS 232 output
9	RXD	RS 232 input
10	USB-	USB communication-
11	USB+	USB communication+
12	FGND	Screened ground wire

The terminal definition table of the host machine

Terminal Sequence	Terminal name	Function
1	BEEP	Signal output of buzzer
2	GLED	Signal output of green indicator
3	RLED	Signal output of red indicator
4	IND 0	Wiegand D0 input
5	IND 1	Wiegand D1 input
6	GND	GND
7	+12V	12V power output (positive pole)
8	RXD	RS 232 input
9	TXD	RS 232 output
10	USB-	USB communication-
11	USB+	USB communication+